

INSTALLATION INSTRUCTION #44E

ELECTRONIC THERMOSTAT

Model No. UTC-2030-(program code #)

and

Model No. UTC-2230-(program code #)

(with 2-pole circuit breaker)

and

Contactor version

These electronic thermostats are designed to control one or more heating cables having a total current draw that does not exceed 30 A for the relay version and up to 60 A for the contactor version. They can be fitted with up to three temperature sensors as required by the application. Because separate temperature sensors are used, they may be installed on the pipe during the initial installation phase while the controller itself may only be installed at a later date.

Features include:

- Universal power supply allowing operation at 120 to 240 Vac without wiring modifications.
- Internal ground fault detection circuitry eliminating the need for an external ground fault device. Alarm only or alarm and trip is activated when ground fault condition is present.
- Three temperature sensor inputs: TS1 for pipe temperature control, TS2 (when enabled) for pipe temperature control at another location on the piping system and TS3 (when enabled) to serve as a high temperature limit for plastic piping protection. An alarm is activated when an enabled “open” or “shorted” sensor is detected.
- Low temperature alarm on both controlling sensors TS1 and TS2. Alarm level is factory set at a dedicated level for each sensor.
- On-off control with a 1°C (1.8 °F) temperature differential for accurate control of piping systems. This close tolerance control can save thousands of kilowatt-hours of power consumption and is ideal to control electric tracing systems in locations where power is costly.
- Override input (factory programmable): timed between 1-48 hours or non-timed.
- Auto-cycle function (when enabled) momentarily turns on heating cable at 24 hours interval to monitor ground fault condition of the load.
- One three-color LED indicator lamp mounted on the door of the controller operates as follows:
 - ❖ Green: When illuminated, the power supply to the controller is ‘on’ and the pipe temperature at the sensor is above the setpoint. When extinguished, the power supply is ‘off’.
 - ❖ Amber: When illuminated, the temperature controller is calling for heat.
 - ❖ Red: When illuminated, this indicates that one of the alarms has been triggered. Controller is not calling for heat.
 - ❖ Amber and Red (alternating): This indicates that one of the alarms has been triggered. Controller is calling for heat.
- Non-volatile memory retains all programmed parameters in the event of a power outage.

Conducted and radiated emissions FCC/DOC statement of compliance

This equipment has been tested and found to comply with the limits for a Class B digital device, pursuant to part 15 of the FCC Rules. These limits are designed to provide reasonable protection against harmful interference in a residential installation. This equipment generates, uses and can radiate radio frequency energy and, if not installed and used in accordance with the instructions, may cause harmful interference to radio communications. However, there is no guarantee that interference will not occur in a particular

installation. If this equipment does cause harmful interference to radio or television reception, which can be determined by turning the equipment off and on, the user is encouraged to try to correct the interference by one or more of the following measures:

- Reorient or relocate the receiving antenna.
- Increase the separation between the equipment and receiver.
- Connect the equipment into an outlet on a circuit different from that to which the receiver is connected.
- Consult the dealer or an experienced radio/TV technician for help.

This Class B digital apparatus complies with Canadian ICES-003.

Installation:

- Be sure that the personnel involved in the installation and servicing is qualified and familiar with electrical equipment, their ratings and applicable codes.
- The wide ambient operating temperature range of the temperature controller allows installation in any convenient location. Considerations should include exposure to weather elements and accessibility for maintenance and testing.
- Mounting hole positions are shown on the drawings in annexes A, B and C.
- Backplate should be removed from the enclosure before any holes are drilled or cut to prevent damage due to flying debris.
- Conduit/cable entries should be made on the bottom of the enclosure to reduce the possibility of water entry. Avoid having holes drilled on the sides adjacent to the electronic components.
- The user may choose to drill 3 mm (*1/8 in*) drain holes on the bottom of the enclosure on both the left and right sides (note that drilling holes in the enclosure compromises the Nema 4 rating).
- Use connector bushings suitable for the enclosure type and install such that the completed installation remains waterproof.

Wiring:

- Always verify wiring connections before applying power to the controller. To avoid injury or equipment damage, do not install or remove wiring while controller is powered.
- To minimize chances of loose connections, lever-operated spring-loaded terminals are used for signal wiring.

- Use shielded, twisted, three-conductor wire for the extension of the RTD leads.
- Use shielded, twisted, two-conductor wire for the extension of the thermistor leads.
- Shields on the temperature sensor wiring should be grounded only at the controller end using the appropriate terminals provided (# 4, 8 and 15).

Note: Some sensor constructions may have continuity between the drain wire and the metal housing at the tip; in this case, the drain wire should not be connected to ground. Drain wire continuity should be verified with a digital multi-meter.

- To minimize the risk of damages to the controller due to a cable fault, the integrity of the heating cable should be verified by:
 - ❖ Performing a high voltage insulation test.
 - ❖ Measuring the load resistance with an ohmmeter.
 - ❖ In both cases, the results should be recorded for future reference.

Sensor type:

This temperature controller can be factory programmed to operate with one of two different types of temperature sensor. By default, the controller is programmed for 100 ohms @ 0 °C (32 °F) Platinum RTD sensor(s). It can also be programmed for 2 252 ohms @ 25 °C (77 °F) thermistor(s) on special request. The last two digits of the controller's catalog number indicate the programming code. Control program codes from 01 to 49 are for use with RTDs and codes from 51 to 99 are for thermistors. Ensure that the proper type of temperature sensor is used with the controller. Program codes are listed in annex E and is identified by a label on the electronics.

Sensor location:

- Install the temperature sensor(s) with aluminum foil tape to enhance heat transfer.
- The controlling sensor is to be taped directly to the pipe wall, 180° away from the heating cable.
- The controlling sensor(s) TS1 and TS2 (when feature enabled) should be located at the expected coldest point(s) of the piping system.
- If controlling a pipe entering a heated building, the sensor(s) must be located at least 3 m (*10 ft*) away from the outside wall to avoid inaccurate temperature sensing.
- The high cable temperature sensor (TS3) is to be taped to an active heating zone of the heating cable (not to the cold lead), within the heat trace channel.

Note: The accurate identification and positioning of the sensor(s) are essential for an efficient and safe operation of the system.

Troubleshooting :

Temperature sensor failure :

This alarm will indicate that one of the sensors is not operating properly. The temperature sensor may fail due to an "open" or "shorted" condition. Ensure that you are using the correct type of sensor i.e. : 3-wire RTD or 2-wire thermistor (refer to program code table in annex E), and that it is wired correctly.

Probable causes of alarm :

- Incorrect or damaged field wiring, "open" leads or excess resistance due to broken or damaged wires or loose connections.
- Damaged or inoperative temperature sensor.
- Wrong type of sensor used.

When using RTDs :

- Ensure that the RTD is a 3-wire 100 ohms @ 0 °C (32 °F) Platinum type.
- Disconnect the RTD wiring from the input terminals.
- Measure the resistance between the source (white) and sense (black) leads at the controller. It should not exceed 40 ohms. Excessive lead resistance will cause a sensor failure alarm and must be corrected. Look for loose terminals, excessive lead length or insufficient wire gauge and correct as necessary.
- Measure the resistance between the source (white) or sense (black) lead and the common (red) lead of the RTD at the controller. It should be between 84 and 178 ohms depending on the probe temperature and lead resistance. Refer to the resistance table in annex F.
- Verify that the RTD is wired correctly. Refer to the wiring diagram in annex D.
- Ensure that the RTD extension wire (when used) is grounded at one end only, normally at the controller terminal.

When using thermistors :

- Ensure that the thermistor is a 2-wire 2 252 ohms @ 25 °C (77 °F) NTC thermistor.
- Disconnect the thermistor wiring from the input terminals.
- Measure the resistance between both leads of the thermistor at the controller. It should be between

75,593 and 152 ohms depending on the probe temperature and lead resistance. Refer to the resistance table in annex F.

- Verify that the thermistor is wired correctly. Refer to the wiring diagram in annex D.
- Ensure that the thermistor extension wire (when used) is grounded at one end only, normally at the controller terminal.

Low temperature alarm (when enabled) :

This alarm will appear when the temperature at the sensor decreases below the low temperature setpoint.

Probable causes of alarm :

- Alarm setpoint too close to maintain temperature setpoint.
- Flow of cold liquid.
- Empty pipe venting out in the atmosphere.
- Damaged or missing thermal insulation.
- Heating cable not sized properly for the application.
- Damaged heating cable.
- Recent power outage allowing pipe to cool under setpoint.

Seemingly incorrect temperature :

Disconnect the temperature sensor from the input terminals at the controller.

When using RTDs :

- To evaluate the temperature at an RTD, measure the resistance from source or sense lead wire to the common lead wire and subtract the resistance measured between source and sense lead wires. The resulting value can be cross-referenced to the table in annex F.

When using thermistors :

- To evaluate the temperature at a thermistor, measure the resistance between both leads. The resulting value can be cross-referenced to the table in annex F.

In both cases, you can usually determine if the temperature obtained from the list is representative of the conditions on the pipe. If you have more than one sensor installed, you can compare the readings. Note that when comparing values of a sensor on the pipe with a sensor on the heating cable, you should ensure that the heating cable has been de-energized for a substantial period of time to allow for both sensors to be in similar temperature environments.

GFI alarm :

This alarm is caused by a ground fault leakage current in excess of the setting.

Probable causes of alarm :

- Alarm level set too close to normal leakage current.

- Damaged cable insulation or moisture presence.
- Poor cable splice or termination.
- Moisture in enclosure that provides a conductive ground path sufficient to trigger the alarm.

UTC-2030 SPECIFICATIONS:

Alarm output : 1 A max, 240 Vac max., 50/60 Hz, SPDT (form C) relay output configured for “fail-safe” operation.

Approvals : CSA “C” - “US” for ordinary locations.

Enclosure: Nema 4, gray painted steel with ¼ turn latch.

Indicator light: Nema 4 multi-function three color LED.

Input voltage range : 120-240 Vac, 50/60 Hz.

Monitoring and alarming : The electronics monitor low temperature, ground fault current and open / shorted temperature sensor(s).

Operating ambient temp.: -40 to +40 °C (-40 to +104 °F).

Power output : 2-pole relay output rated 30 A - 240 Vac.

Terminal blocks:

Power terminals for #22 to #8 AWG

Signal terminals for #28 to #12 AWG

Power in: L1, N or L2.

Heater out: H1, N or H2

Sensors: TS1: #1-2-3-4.

TS2: #5-6-7-8.

TS3: #12-13-14-15.

Alarm relay: #9-10-11.

Alarm reset: #16-17.

Override input: #18-19.

Valid temperature range: -40 to +100 °C (-40 to +212 °F).

FACTORY PROGRAMMABLE:

Auto-cycle : When the temperature controller is energized, and then at 24 hours intervals, the controller performs an auto-cycle test by turning on the load to measure the ground fault leakage current. If the measured ground fault current is above the set level, the ground fault current alarm is activated.

Ground fault detection : Factory adjustable to trip or alarm only. Setting @ 30 or 100 ma.

Remote override : The user may force the unit on/off via a remote dry contact. Factory adjustable to operate in timed (1-48 hours) or non-timed mode.

Temperature control : three 3-wire 100 Ω @ 0 °C (32 °F) Platinum RTD (alpha=0,00385 Ω/Ω/°C), lead compensated to 20 Ω per lead.

or

three 2-wire 2 252 Ω @ 25 °C (77 °F) NTC Thermistor.

Deadband : 1 to 5 °C (1.8 to 9 °F) see ANNEX E.

Control temperature

setpoint range: -5 to 75 °C (23 to 167 °F) see ANNEX E.

Low temperature alarm : Feature can be enabled to provide low temperature alarm on TS1 and TS2.

Low temperature

setpoint range: -10 to 75 °C (14 to 167 °F) see ANNEX E.

High cable temperature: The third temperature sensor (referred to as TS3) is used as a high cable temperature limit for plastic piping system protection. When TS3 is enabled, the high limit feature will override demand for heat and shut off the load when a high cable temperature condition is reached.

High temperature

set point range: 25 to 100 °C (77 to 212 °F) see ANNEX E.

UTC-2230 SPECIFICATIONS :

Same specifications as the UTC-2030, with the addition of :

Circuit breaker : 2-pole, 30 A, 240 Vac, pre-wired to the temperature control board.

Terminal blocks: Incoming power lugs at the circuit breaker for: #14 to #4 AWG

CONTACTOR VERSION SPECIFICATIONS :

Same specifications as the UTC-2030, except for the following :

Sequence of number is : UTC-VPAA-xx

‘V’ in the catalog number denotes the operating voltage, i.e. : 2 for 208, 4 for 480 or 6 for 600 .

‘P’ in the catalog number denotes the number of poles on the circuit breaker, i.e. : 2 or 3.

‘AA’ in the catalog number denotes the amperage of the circuit breaker,
i.e. : 15, 20, 25, 30, 35, 40, 45, 50 or 60.

‘xx’ in the catalog number denotes the control program code (see annex E).

Input voltage : 208, 480 or 600 Vac, 50/60 Hz, 3-phase / 4-wire.

Power output : 3-pole contactor output rated 60 A - 600 V ac.

Terminal blocks: Power in terminals; L1, L2 and L3: #14 to # 4 AWG
Heater terminals; H1, H2 and H3: #14 to # 3 AWG
Neutral terminals: #14 to # 6 AWG

UTC-2030
Thermostat électronique / Electronic thermostat

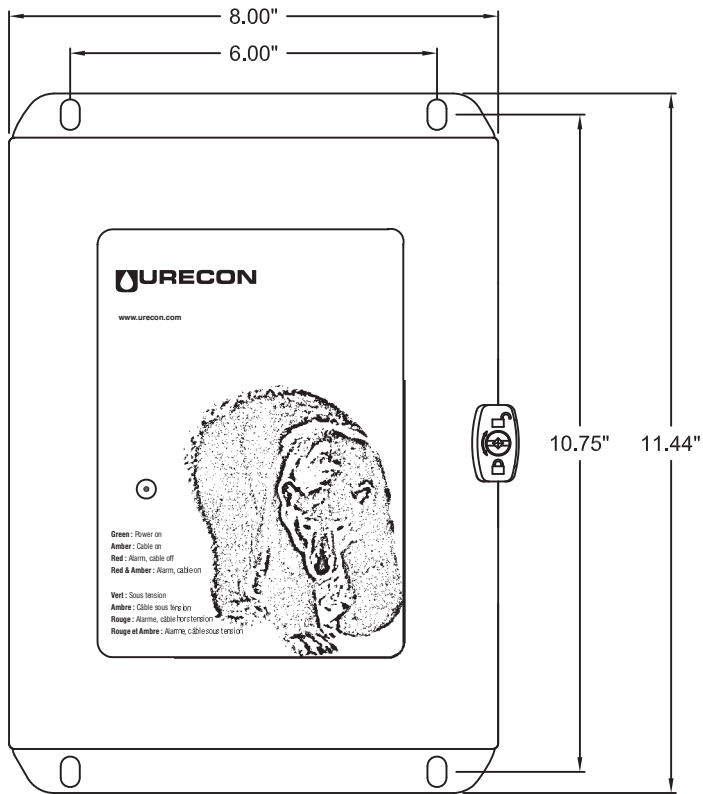

ÉLÉVATION / FRONT VIEW

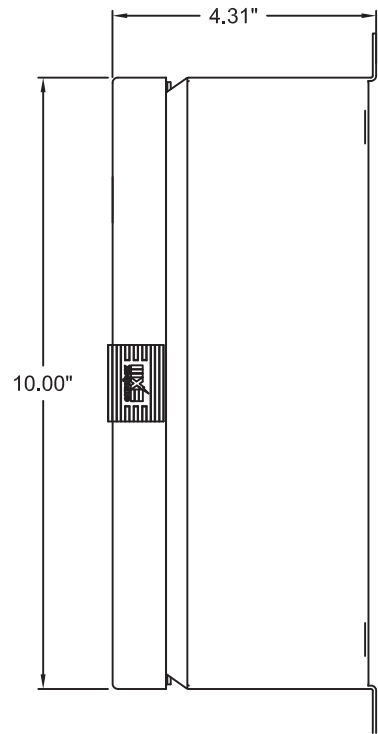

PROFIL / LEFT SIDE VIEW

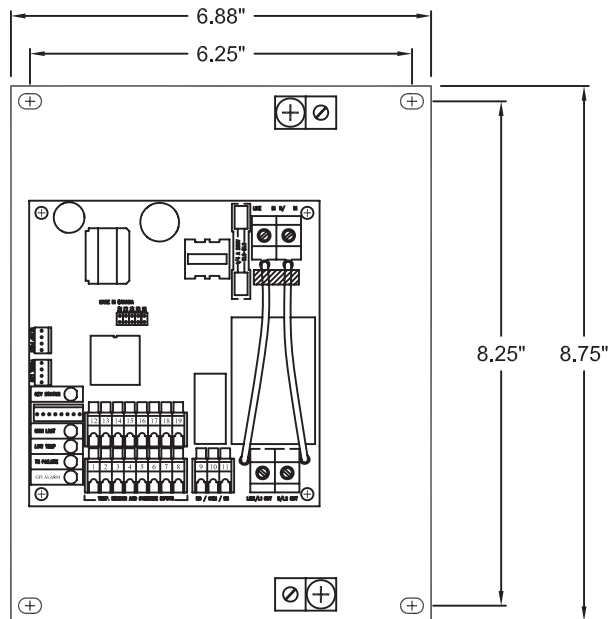

PLAQUE DE FOND / BACKPLATE

ANNEXE / ANNEX **B**

UTC-2230

Thermostat électronique / Electronic thermostat

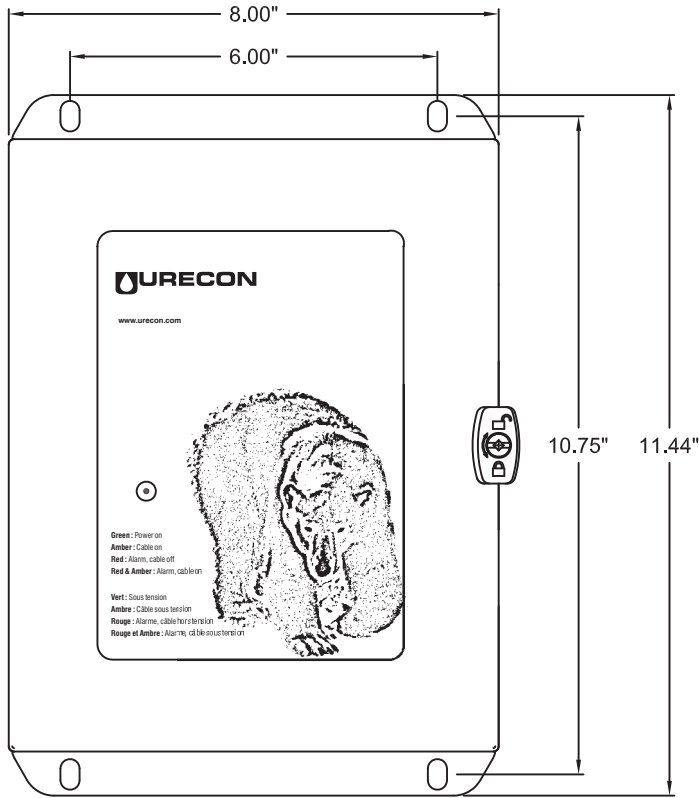

ÉLEVATION / FRONT VIEW

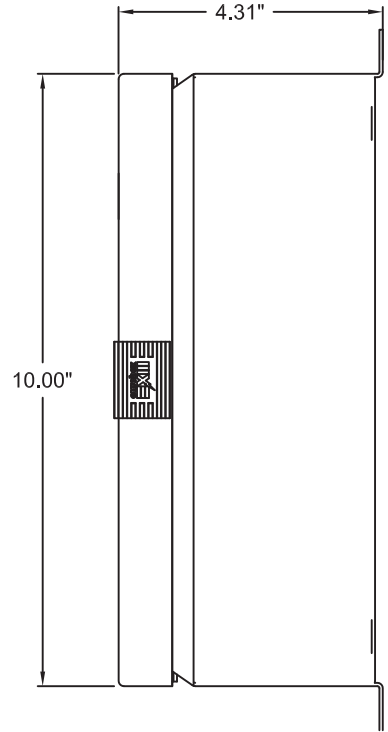

PROFIL / LEFT SIDE VIEW

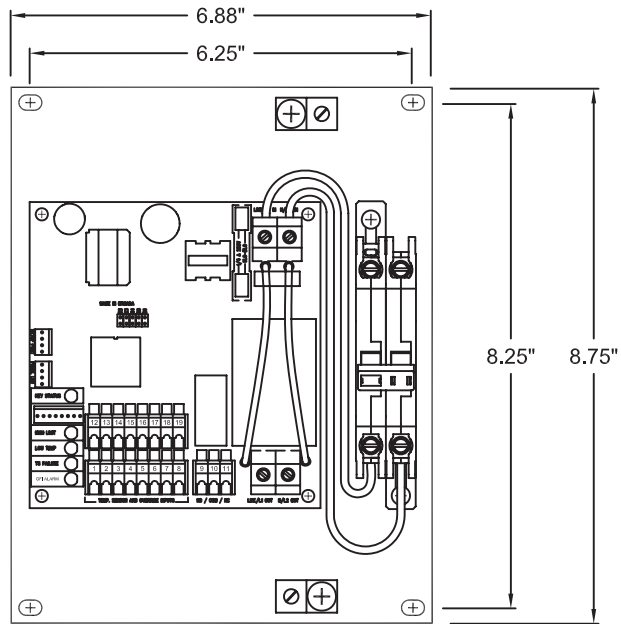

PLAQUE DE FOND / BACKPLATE

Thermostat électronique à contacteur / Contactor version electronic thermostat

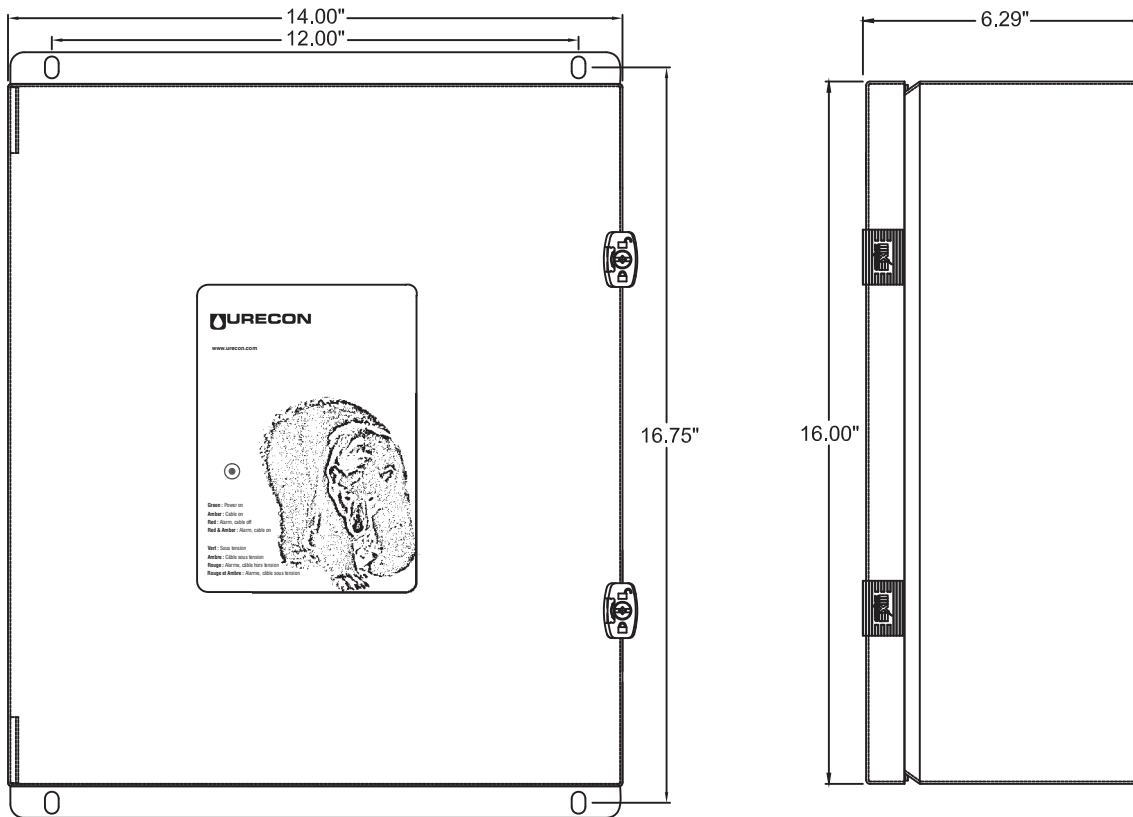

ÉLÉVATION / FRONT VIEW

PROFIL / LEFT SIDE VIEW

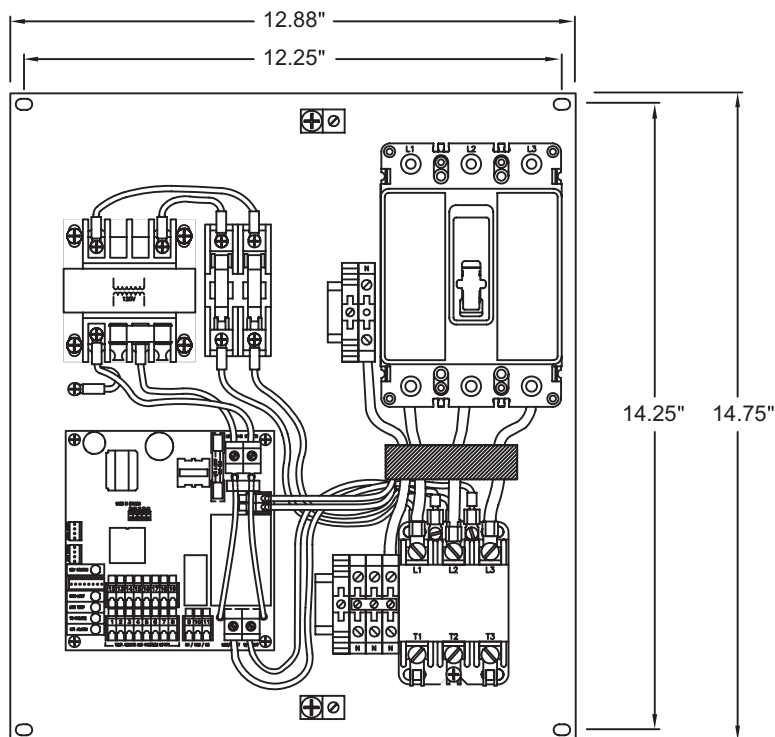

PLAQUE DE FOND / BACKPLATE

Schéma de câblage / Wiring Diagram

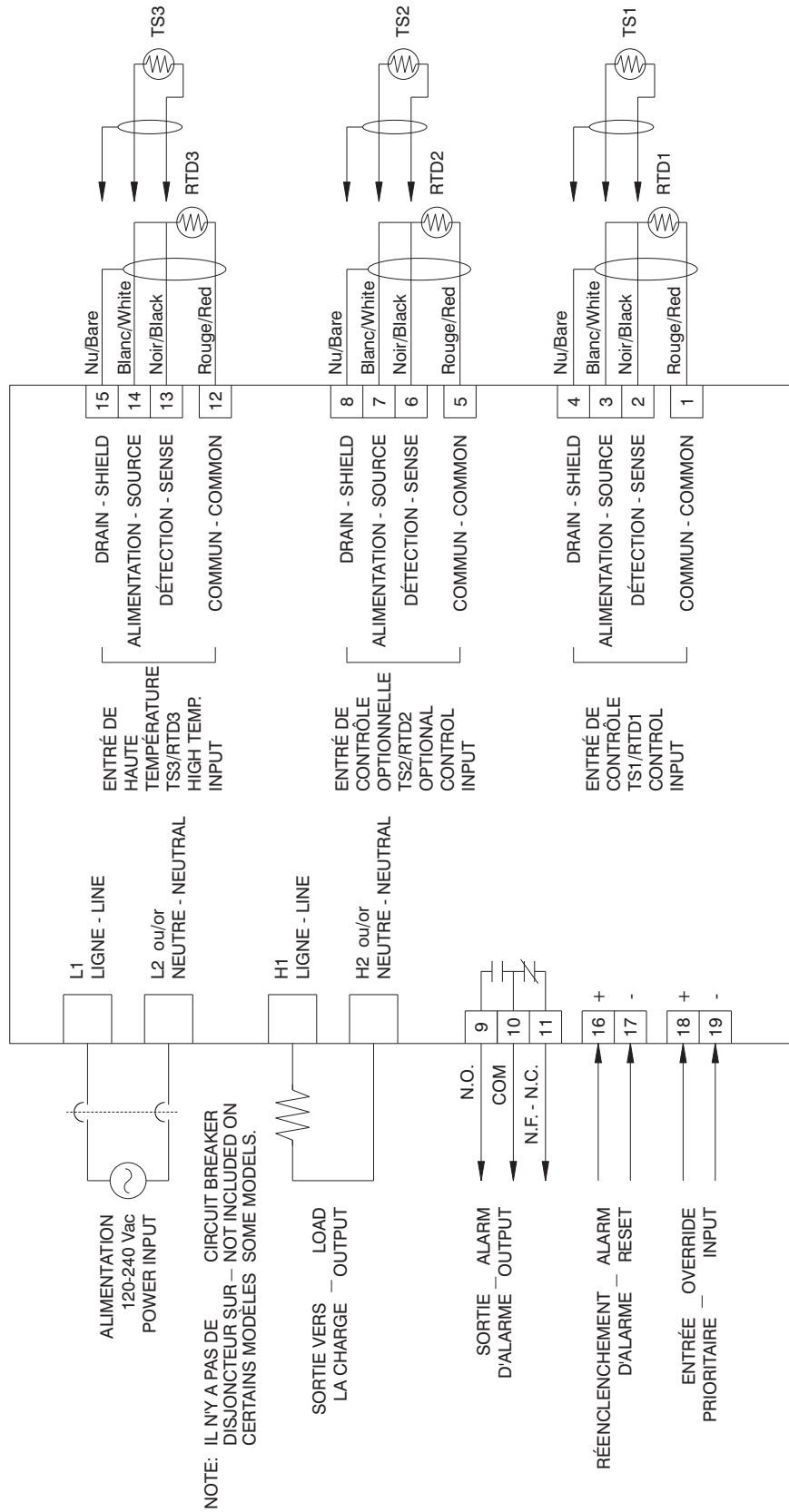

ANNEXE / ANNEX **E**

UTC-2030-xx, UTC-2230-xx, UTC-VPAA-xx

xx doit être remplacé par le code de programmation approprié

xx is to be replaced by the appropriate program code number

code de programmation pour RTD	Capteur de contrôle TS1 (alarme en indice) Température	Capteur de contrôle TS2 (alarme en indice) Température	Capteur de haute température TS3 Température	code de programmation pour thermistance
RTD program code	Controlling sensor TS1 (alarm in subscript)	Controlling sensor TS2 (alarm in subscript)	High temperature sensor TS3	Thermistor program code

POUR TUYAU DE PLASTIQUE FOR PLASTIC PIPE	01	3 °C (37.4 °F)	–	65 °C (149 °F)	51	POUR TUYAU DE PLASTIQUE FOR PLASTIC PIPE
	02	3 ₁ °C (37.4 _{33.8} °F)	–	65 °C (149 °F)	52	
	03	5 °C (41 °F)	–	65 °C (149 °F)	53	
	04	5 ₃ °C (41 _{37.4} °F)	–	65 °C (149 °F)	54	
	05	10 °C (50 °F)	–	65 °C (149 °F)	55	
	06	10 ₅ °C (50 ₄₁ °F)	–	65 °C (149 °F)	56	
	07	15 °C (59 °F)	–	65 °C (149 °F)	57	
	08	15 ₁₀ °C (59 ₅₀ °F)	–	65 °C (149 °F)	58	
	11	3 °C (37.4 °F)	3 °C (37.4 °F)	65 °C (149 °F)	61	
	12	3 ₁ °C (37.4 _{33.8} °F)	3 ₁ °C (37.4 _{33.8} °F)	65 °C (149 °F)	62	
	13	5 °C (41 °F)	5 °C (41 °F)	65 °C (149 °F)	63	
	14	5 ₃ °C (41 _{37.4} °F)	5 ₃ °C (41 _{37.4} °F)	65 °C (149 °F)	64	
	15	10 °C (50 °F)	10 °C (50 °F)	65 °C (149 °F)	65	
	16	10 ₅ °C (50 ₄₁ °F)	10 ₅ °C (50 ₄₁ °F)	65 °C (149 °F)	66	
	17	15 °C (59 °F)	15 °C (59 °F)	65 °C (149 °F)	67	
	18	15 ₁₀ °C (59 ₅₀ °F)	15 ₁₀ °C (59 ₅₀ °F)	65 °C (149 °F)	68	

POUR TUYAU DE MÉTAL FOR METAL PIPE	21	3 °C (37.4 °F)	–	–	71	POUR TUYAU DE MÉTAL FOR METAL PIPE
	22	3 ₁ °C (37.4 _{33.8} °F)	–	–	72	
	23	5 °C (41 °F)	–	–	73	
	24	5 ₃ °C (41 _{37.4} °F)	–	–	74	
	25	10 °C (50 °F)	–	–	75	
	26	10 ₅ °C (50 ₄₁ °F)	–	–	76	
	27	15 °C (59 °F)	–	–	77	
	28	15 ₁₀ °C (59 ₅₀ °F)	–	–	78	
	31	3 °C (37.4 °F)	3 °C (37.4 °F)	–	81	
	32	3 ₁ °C (37.4 _{33.8} °F)	3 ₁ °C (37.4 _{33.8} °F)	–	82	
	33	5 °C (41 °F)	5 °C (41 °F)	–	83	
	34	5 ₃ °C (41 _{37.4} °F)	5 ₃ °C (41 _{37.4} °F)	–	84	
	35	10 °C (50 °F)	10 °C (50 °F)	–	85	
	36	10 ₅ °C (50 ₄₁ °F)	10 ₅ °C (50 ₄₁ °F)	–	86	
	37	15 °C (59 °F)	15 °C (59 °F)	–	87	
	38	15 ₁₀ °C (59 ₅₀ °F)	15 ₁₀ °C (59 ₅₀ °F)	–	88	

**Capteurs de température utilisés avec les
thermostats électroniques de la série UTC.**

**Temperature sensors used with the
UTC line of electronic thermostats.**

Thermistance / Thermistor (Modèle précédent / Previous model) de / of 2 252 ohms @ 25 °C (77 °F)	
Température Temperature	Résistance Resistance
-40 °C (-40 °F)	75 593 Ω
-35 °C (-31 °F)	54 542 Ω
-30 °C (-22 °F)	39 789 Ω
-25 °C (-13 °F)	29 331 Ω
-20 °C (-4 °F)	21 839 Ω
-15 °C (5 °F)	16 416 Ω
-10 °C (14 °F)	12 453 Ω
-5 °C (23 °F)	9 529,2 Ω
0 °C (32 °F)	7 353,0 Ω
5 °C (41 °F)	5 719,1 Ω
10 °C (50 °F)	4 482,3 Ω
15 °C (59 °F)	3 538,8 Ω
20 °C (68 °F)	2 813,6 Ω
25 °C (77 °F)	2 252,0 Ω
30 °C (86 °F)	1 814,2 Ω
35 °C (95 °F)	1 470,6 Ω
40 °C (104 °F)	1 192,2 Ω
45 °C (113 °F)	983,4 Ω
50 °C (122 °F)	810,9 Ω
55 °C (131 °F)	672,2 Ω
60 °C (140 °F)	560,1 Ω
65 °C (149 °F)	468,9 Ω
70 °C (158 °F)	394,5 Ω
75 °C (167 °F)	333,3 Ω
80 °C (176 °F)	282,9 Ω
85 °C (185 °F)	241,1 Ω
90 °C (194 °F)	206,3 Ω
95 °C (203 °F)	177,2 Ω
100 °C (212 °F)	152,8 Ω

RTD de Platine / Platinum RTD (Modèle courant / Current model) de / of 100 ohms @ 0 °C (32 °F)	
Température Temperature	Résistance Resistance
-40 °C (-40 °F)	84,27 Ω
-35 °C (-31 °F)	86,25 Ω
-30 °C (-22 °F)	88,22 Ω
-25 °C (-13 °F)	90,19 Ω
-20 °C (-4 °F)	92,16 Ω
-15 °C (5 °F)	94,12 Ω
-10 °C (14 °F)	96,09 Ω
-5 °C (23 °F)	98,04 Ω
0 °C (32 °F)	100,00 Ω
5 °C (41 °F)	101,95 Ω
10 °C (50 °F)	103,90 Ω
15 °C (59 °F)	105,85 Ω
20 °C (68 °F)	107,79 Ω
25 °C (77 °F)	109,73 Ω
30 °C (86 °F)	111,67 Ω
35 °C (95 °F)	113,61 Ω
40 °C (104 °F)	115,54 Ω
45 °C (113 °F)	117,47 Ω
50 °C (122 °F)	119,40 Ω
55 °C (131 °F)	121,32 Ω
60 °C (140 °F)	123,24 Ω
65 °C (149 °F)	125,16 Ω
70 °C (158 °F)	127,07 Ω
75 °C (167 °F)	128,98 Ω
80 °C (176 °F)	130,89 Ω
85 °C (185 °F)	132,80 Ω
90 °C (194 °F)	134,70 Ω
95 °C (203 °F)	136,60 Ω
100 °C (212 °F)	138,50 Ω